

# Dynamics of Cytochrome bf Complex of Photosynthesis Apparatus

M. Jalal Kamali and M. Shojaei\*

Semiconductors Department, Photonics Research School, International Center for Science, High Technology and Environmental Sciences (ICST), Mahan, Kerman, Iran.

\*Corresponding Author Email: [msh@mail.uk.ac.ir](mailto:msh@mail.uk.ac.ir)

**Abstract**— Photosynthesis is a process under which, the radiative energy is converted into the chemical one. Compared to the man-made devices, the photosynthesis apparatus is much more efficient. This high efficiency comes from its elaborate structure, very fast transition rates and a complex electron and proton transfer chain among the subunits of the apparatus. Its main subunits (Photosystem I (PSI), bf complex and photosystem II (PSII)) are connected through different mobile carriers.

Among these, the cytochrome bf complex, connecting PSI and PSII, plays an essential role in the photosynthetic process. During recent years, the function and structure of this complex has been studied using different experimental methods. On the other hand, to explain its dynamic, the complex has been mathematically modeled. In this paper, based on a kinetic model, proposed earlier by one of the authors, an improved model has been introduced and the new experimental data has been analyzed.

The model is a comprehensive one that considers the different components of the complex and also its relation with mobile charge carriers (plastocyanin and plastoquinones). Via comparison with experimental data, the rate of redox reactions has been determined by using the mathematical methods of parameter identification.

Despite the large number of parameters, nonlinearity and coupling of governing equations, and indeterminacy of the initial values, the results of modeling conforms well to the experimental data. This may help to a better understanding of the bf complex structure and behavior, in particular, and of the photosynthesis apparatus as a whole.

**Keywords:** Photosynthesis, Solar energy conversion, Cytochrome bf complex, Kinetic

model, Parameter identification, Mathematical modeling.

## I. INTRODUCTION

Solar energy conversion is considered as a candidate solution for the energy crisis. This can be done by photovoltaic or photoelectrochemical processes [1]-[3]. The former process may be implemented by solar cells and the latter one by artificial or natural photoelectrochemical cells [4]-[6]. Both could convert the freely available solar energy to electrical energy in a nearly clean and ecological-friendly manner. The main problem with them is the not very high efficiency of the cells. There is a promising trend to overcome this deficiency, by adopting the natural direction [7]-[9].

During the photosynthesis process, the solar energy conversion has been done more efficiently by solar cell natural counterparts (green leaves). Although, the overall performance of photosynthesis is not very high, the efficiency of the light converting stage exceeds %95. Additionally, unlike solar cells, the converted energy is stored into stable and very convenient chemical forms (organic compounds, such as sugar). This means that the photosynthesis can be considered as an efficient direct way for producing fuels [10]-[12]. In fact, the different photosynthesis systems (plants, algae, and many species of bacteria) are efficient photonic devices that are very well optimized through the natural evolution process. Utilizing this elaborate solution to optimize our crude devices requires a full understanding of the photosynthesis apparatus.

Photosynthesis has been investigated for a few centuries, but only recently its full scheme has been determined [13, 14]. The photosynthesis is a multistage process for converting light energy to chemical one. It consists of a complex set of reduction-oxidation reactions and some cyclic or noncyclic electron transfer chain accompanied by hydrogen transfer across membrane containing the photosynthetic apparatus. This is composed of several components that are localized and distributed on the thylakoid membrane of the higher plants. There are also some mobile carriers that facilitate the energy transfer between different parts. The main components are: Photosystem I (PSI), Photosystem II (PSII), bf complex cytochrome, and ATP synthase. The primary photosynthetic processes could be divided into three stages: 1) light absorption in reaction centers (RCs) by photosynthetic pigments and transferring their energy to excited electrons, 2) charge separation in RCs, and 3) electron movement through electron transfer chain. The latter, accompanied with hydrogen transfer, leads to the formation of the first stable compounds (ATP and NADP). In the secondary stages (so called dark reactions), these products do the carbon fixation and make the final products of the photosynthesis (carbohydrates). The general scheme of the photosynthetic apparatus and different charge transfer chains are shown in Fig. 1.

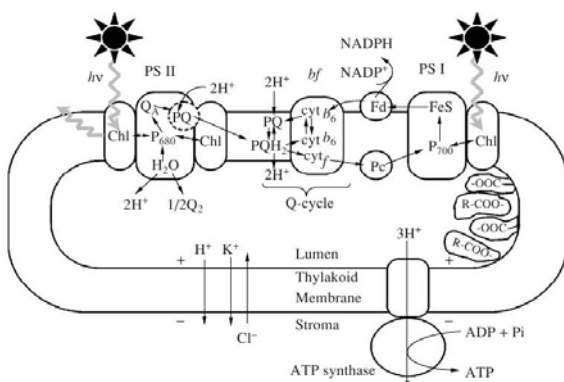
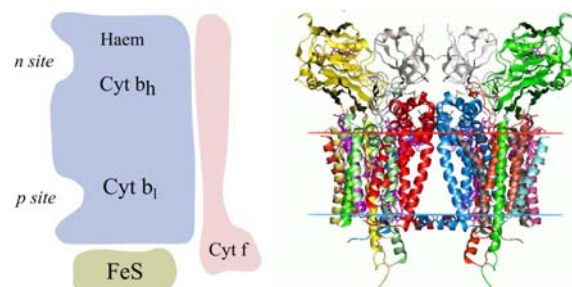

**Fig. 1** The general scheme of the photosynthetic apparatus.

Among the components, the cytochrome bf complex is responsible for the coupling of

electron and also proton transmembrane transport. It connects PSII and PSI and plays an important role in the electron transfer chain and energy balance, so its function is vital in the whole process. During two recent decades, there were many experimental studies concerning the structure and function of this cytochrome [15-18]. It has been investigated using different experimental methods (spectroscopic, ESR, X-ray, laser induced ...). Although, its final static structure has been determined in 2003 [15], there is a trend to find its other probable conformations and details of the dynamics of the structure, yet.

As we know from these studies, it is composed of four main subunits: 1) cytochrome b, containing two heme groups (low potential  $b_l$  and high potential  $b_h$ ), 2) cytochrome f, 3) Rieske iron-sulfur protein, and 4) the so called subunit IV. It also contains additional chromophores, namely *chlorophyll a*,  *$\beta$ -carotene* and an atypical heme (*heme x*). A schematic of bf complex is shown in Fig. 2 along with its molecular structure. It has two binding sites n and p (located near the external and internal surfaces of the membrane, respectively) for making connection with mobile charge carriers, quinones, and one binding site on the other side for binding with plastocyanin. These couple the complex with PSII and PSI to complete the electron transfer chain and making the transmembrane proton gradient.



**Fig. 2** Cytochrome bf complex molecular structure and its schematic view [19].

Apart from the experimental studies, there has been a wide range of mathematical modeling to achieve a better understanding of complex behavior. They considered the charge

distribution among different subunits of the complex and/or its coupling with PSI and PSII, and the probable conformational rearrangements. The models range from kinetic models with different number of parameters [20]-[24] to simulation modeling (such as multiparticle direct modeling) of the system [23],[25]-[28]. Also, there are a large number of models related to the other parts of the primary and secondary stages of photosynthetic processes [20], [23].

## II. MATHEMATICAL MODELING

Since, the cytochrome bf complex can not be directly excited by light, and its changes are indirect consequences of reduction-oxidation processes that are triggered by light excitation of photosystem I and photosystem II, the determination of its kinetics from optical experiments (such as spectroscopic studies) is very complicated and in some cases impossible. It is so because the contribution of each of the reduction-oxidation processes in the resulting absorption spectrum is not clear and hence, a model describing the underlying processes must be introduced to complete the scheme.

There are two main approaches for the modeling of physical processes in biological systems: first, models based on the differential equations describing the dynamics/distribution of the system and its parts. Amongst them the kinetic ones are the most common that give the rate constants for various reactions or population distribution of system in its available states. This is especially useful for the cases that the rate constants of some of the reactions could not be determined explicitly. Often, these models contain parameters that may be varied to fit the modeling results with experimental data. This requires the mathematical methods of parameter identification and/or solving an inverse problem. Often, the number of parameters is so high that the whole process is not a straightforward one. Second, models that use the very fundamental laws of physics and statistical mechanics, to simulate the processes occurring in the system. These models may

give a more clear picture of the processes and interactions, but usually are less informative and require a large computing power. In some cases, both kinds of modeling are done to have a full picture of underlying processes.

### A. *The Kinetic Model*

As stated earlier, interpreting the results of the optical experiments on the cytochrome bf complex requires an appropriate mathematical model. There have been proposed a couple of models describing the cytochrome bf complex, its structure and function. Due to the complexity of the cytochrome and its many subunits and connections with other components, even the simplest model leads to a multiparameter, multivariable mathematical problem with partially undetermined initial conditions. In a previous work [21] one of the authors with co-workers from biological faculty of Moscow state university have introduced a kinetic model taking into account the most aspects and reactions of the complex. In this work, we use the same model, extend it and apply it to the newly found experimental results to find more accurate values for the rate constants of reactions.

In this model, the following parts are considered:

- Rieske iron-sulfur center (FeS), in equilibrium with cytochrome f through resonance.
- High potential heme of cytochrome b ( $b_h$ ).
- Low potential heme of cytochrome b ( $b_l$ ).
- Binding site p (in the luminal (internal) side of thylakoid membrane) for plastoquinol ( $PQH_2$ ) oxidation.
- Binding site n (in the stromal (external) side of thylakoid membrane) for plastoquinone (PQ) oxidation.

Depending on the reduction state of cytochrome subunits, the bf complex may be in one of the 12 possible states. The complexes in the thylakoid membrane are distributed

among these states with a probability evolving according to the rate equations. The mobile carriers ( $PQH_2$  and  $PQ$ ) change their reduction-oxidation states by connecting to the binding sites n and p. They move across the membrane and so may be in the stromal or luminal side of the membrane.

Model assumes that the bf complex operates in the so called Q-cycle, so the following processes are going on.

In the first turn-over, upon reduction by PSII,  $PQH_2$  diffuses in the membrane and is oxidized in the luminal p site of the bf complex, whereby one electron goes to the Rieske FeS center (high-potential path) and then to the plastocyanin:

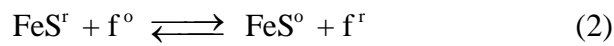
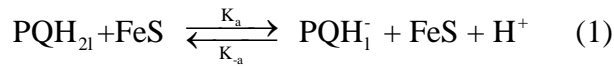

here subscripts s and l denote the stroma and lumen respectively and superscripts r and o shows the reduced or oxidized state of the relevant subunit or carrier.

Another electron goes to oxidized  $b_l$  (low-potential path) and passing through the following equations will be transferred to the stromal quinones on the n site:

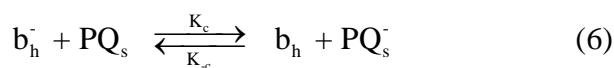
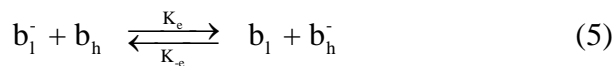
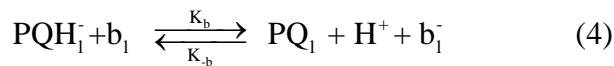

This scheme repeats in the second turn-over and in the last stage, uptaking two protons from the stroma and getting one electron during transmembrane electron transfer ( $b_l$ - $b_h$ ),  $PQ_s^-$  changes to the  $PQH_2$ :

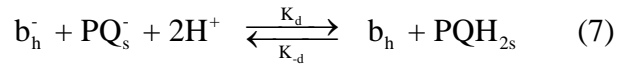

Since, the electron transfer from FeS to cytochrome f is very fast, they could be considered in resonance, and hence the equations (2) and (3) could be combined to give the following one:



It is noteworthy that in this case, due to the compactness of the components, the direct transfer of electrons from Rieske center to plastocyanin is also possible.

Additionally, the following processes also are taken into account in the model:

- electrochemical potential across membrane
- plastoquinone diffusion from stroma to lumen and quinone diffusion in the reverse direction
- transmembrane proton diffusion

More details could be found in [21].

In this work, we also included the complex connection with photosystem I. This interaction is accomplished by the plastocyanin in the reduction state. Reduced PCs interact with the main pigment of PSI, namely  $P_{700}$ , through the following reaction:



## B. Governing Equations

The aforementioned model leads to a set of rate equations for the reactions. This is a system of 28 nonlinear coupled differential equations. The general form of the equations is as:

$$\frac{dP_i}{dt} = \sum_{j=1}^l (P_j K_{ji} - P_i K_{ij}) \quad (10)$$

where,  $P_i$  is the probability of the complex being in state  $i$ ,  $K_{ij}$  is the rate constant for transition from state  $i$  to state  $j$ . The transition from other states to  $i$  is considered as positive and the transition from state  $i$  to other states as negative. The summation is over all intervening states ( $l$ ) that make contribution to the desired state. There are also, similar equations for the mobile carriers.

The initial values are given as  $P_i(0) = b_i$  for all  $i$ 's.

It must be noted that the  $K_{ij}$  transition rates are unknown parameters. So, the problem is an inverse one, that is, knowing the governing equations forms and some indirect experimental results, we must find the appropriate parameters. For our model, the number of unknown parameters counts to more than 20. Also, for many of the states, the initial conditions are either unknown or there is only a rough estimation.

In addition, the probabilities for  $K_{ij}$  transition rates, in general, are not constant. They depends on other parameters and variables such as temperature, external electric fields, transmembrane electrical potential, and also on the bf complex state as a whole, that is on its localization and density in the thylakoid membrane, its conformational changes, etc. In our model, the effect of the photoinduced membrane electrical potential is also considered.

### C. Experimental Data Used in the Modeling

In the relevant literature, there is a wide range of experiments regarding bf complex structure and dynamics. These have been done on different samples, under varying conditions and by using various experimental methods. For example, the chosen samples range from intact plant leaves, cyanobacteria, and algae to isolated thylakoid membranes and bf complexes under presence of different inhibitors [20, 22, 29-31]. Often, the transient behavior of the whole system or part of it after undergoing an intensive light flash has been considered. The flash induced absorbance

change at appropriate wavelengths, the fluorescence, and/or reduction-oxidation kinetics of cytochromes has been measured to describe this behavior. In some cases, the continuous radiation is applied. The experiments also can be divided into *in vitro* and *in vivo* ones. Apart from spectroscopic methods, other techniques such as electrochromic signals (ECS) are used, too.

In most of the experiments, the rate constants are not obtained directly, but they must be determined indirectly from combination of the results under the framework of a reasonable model. In some cases additional assumptions is required, too. This diversity of data makes their comparison very difficult. To solve and test our model, we focused on the more reliable results that obtained under standard conditions. Among the first works is Hope's one [22]. In this work, the flash-induced redox change of complex from pea chloroplast suspension has been measured in a 20 ms interval by deconvoluting absorbance changes at appropriate wavelengths. The electrochromic signals are also registered. The time variation of reduced cytochromic heme concentration ( $[b_h]$ ), oxidized cytochrome f concentration ( $[f^o]$ ), oxidized plastocyanin concentration ( $[PC^o]$ ) and proton concentration in the lumen side of thylakoid membrane ( $[H_1^+]$ ) after application of a 15ns pulse has been obtained. A more recent review and analysis of their results and a comparison between *in vivo* and *in vitro* results could be found in [30]. Apart from these experiments, we used the newer *in vivo* results from Chow [31]. The experiment has been done on intact leaf disks of several plant species (cucumber, dwarf bean, broad bean and soy bean) using laser light in different wavelengths and the absorbency changes at these wavelengths is measured. The ECS, as an indicative of a transmembrane electric field is also measured. Along with the previously mentioned variation of subunits concentrations, this paper gives the time variation of the main pigment of photosystem I, that is  $[P_{700}]$ , in its oxidized form. Using this, we have a more complete scheme of the electron transfer chain.

### III. RESULTS AND DISCUSSIONS

Using the above mentioned experimental results, we solved the inverse problem of parameter identification of our mathematical model to obtain the rate constants of the kinetic equations.

The calculations were done using three independent numerical programs. The problem considered as an optimization one, where the minimization of the cumulative difference between experimental results and those obtained from modeling (by choosing an arbitrary set of parameters and initial conditions) was counted as the target. The criterion for minimization was the simultaneous least square difference of all of the curves. Nonlinear differential equations were solved using Runge-Kutta numerical method. As the search strategy to find the appropriate parameters, we used the lattice method in the parameter space and the Hook-Jeevse algorithm as a fast and reliable search method.

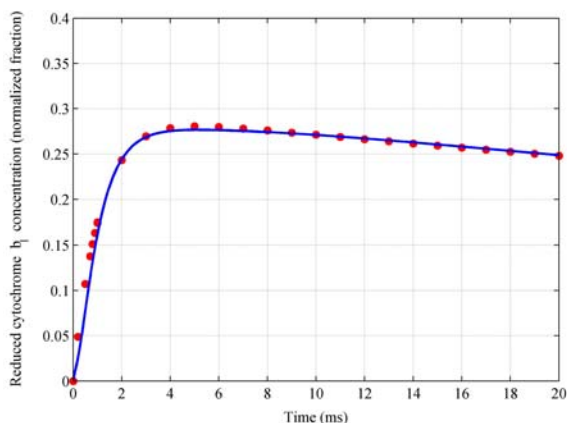

**Fig. 3** Time variation of reduced  $b_1$  concentration after application of an intense short light flash at time prior to  $t=0$ . The concentration is shown as the normalized fraction of all  $b_1$  subunits. Circles denote the experimental data and the continuous curve shows the modeling outcome.

The ambiguity in the uniqueness of the parameters that lead to the minimum of the target function is one of the common problems in solving nonlinear equations. Another problem is related to the absoluteness of the minimum. To overcome these, we used the fact that if the minimum is an absolute and

unique one, the result must not be very sensitive to the choice of initial conditions in a reasonable range of possible ones.

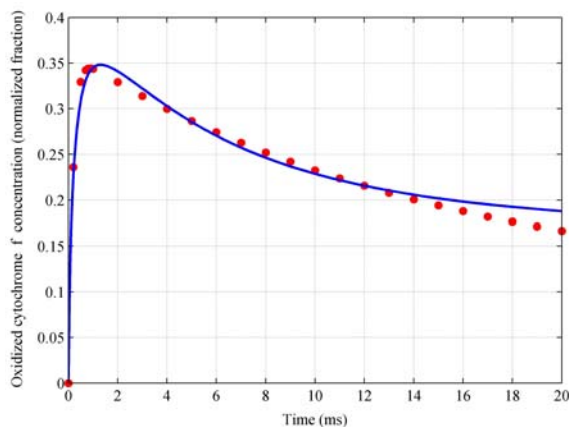

**Fig. 4** Time variation of oxidized cytochrome  $f$  concentration after application of an intense short light flash at time prior to  $t=0$ . The concentration is shown as the normalized fraction of all  $f$  subunits. Circles denote the experimental data and the continuous curve shows the modeling outcome.

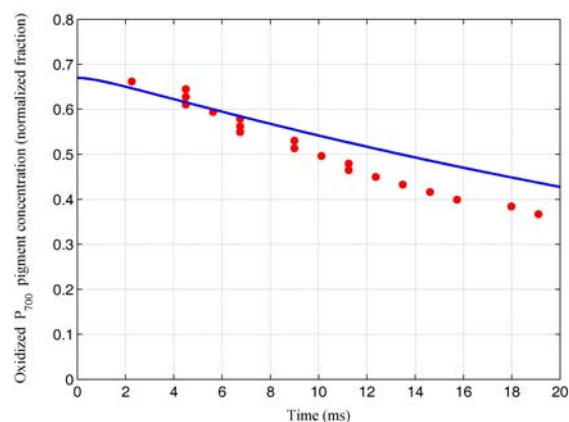

**Fig. 5** Time variation of oxidized  $P_{700}$  pigment concentration after application of an intense short light flash at time prior to  $t=0$ . The concentration is shown as the normalized fraction of all  $P_{700}$  subunits. Circles denote the experimental data and the continuous curve shows the modeling outcome.

The model was solved and time variations of reduction-oxidation of different subunits of bf complex were obtained. In any case we got a set of parameters, so that these variations were in simultaneous accordance with three experimental curves of cytochrome  $b_1$  oxidation, cytochrome  $f$  reduction and  $P_{700}$  pigment reduction. Figures 3 to 5 show the modeling outcome and the corresponding

experimental results for these variables. In Fig. 3 the reduced  $b_1$  concentration variation after application of an intense short light flash is depicted. Similar results are shown for cytochrome  $f$  in Fig. 4. Reduction-oxidation variation of  $P_{700}$  pigment is pictured in Fig. 5. In all figures, the dots show the experimental results and the continuous curves are representative of modeling results.

As figures show, a good accordance has been achieved. The corresponding parameters (rate constants and initial values), also have reasonable values. The rate constants obtained from this kinetic model is listed in table 1 for different reactions (as defined in equation 1 and equations 4 through 9).

**Table 1:** Rate constants for distribution of cytochrome  $bf$  complexes amongst their possible states according to the results of modeling. The equilibrium constant can be used to derive the rate constant in the reverse direction.

| Reaction No. | Constant | Direct constant $K$ ( $s^{-1}$ ) | Equilibrium constant $K/K$ . |
|--------------|----------|----------------------------------|------------------------------|
| 1            | $k_a$    | 1770                             | 3.1                          |
| 4            | $k_b$    | 1800                             | 9                            |
| 6            | $k_c$    | 2200                             | 12                           |
| 7            | $k_d$    | 1000                             | 25                           |
| 5            | $k_e$    | 750                              | 5                            |
| 8            | $k_f$    | 2000                             | 8                            |
| 9            | $k_g$    | 25                               | 5                            |

Additionally, regarding the transmembrane proton gradient, considered in the model, the volume thylakoid membrane capacitance has been found to be  $2 CV^{-1}I^{-1}$ .

#### IV. CONCLUSION

The dynamics of the cytochrome  $bf$  complex of photosynthetic apparatus has been modeled. A kinetic model based on the fundamental reactions occurring between different subunits of the complex has been introduced and extended to consider the population distribution of the complex protein amongst its various states. The relation between  $bf$  complex and its neighboring parts of the apparatus (PSI and PSII), and the effect of PH

of the environment (proton gradient across membrane) has been taken into account, too. The appropriate experimental results from literature has been picked out and fed into the model to calculate the rate constants of the reactions.

The model achieved a reasonable conformance with experimental data. The obtained constant rates also agree with the theoretical considerations and previously direct or indirect observations. The agreement is more pronounced compared with other similar models (e.g. [31]). It seems that it is so, because the proposed model is more comprehensive than earlier ones and considers all of the relevant reactions and connections with other parts. The good simultaneous agreement between model outcome and experimental results for three various data sets shows that the nonlinear parameter identification problem has been solved with adequate accuracy. The kinetic model was able to determine the rate constant of some reactions that are not directly measurable (such as electron transfer rate from  $PQH_2$  to FeS).

It must be noted that the kinetic models have their own advantages and disadvantages. As these models are statistical ones, they are not very sensitive to the spatial distribution and the specific conformation of the objects, and also require a large number of particles to be present that is not exactly true in this case. So, despite the popularity of these models in mathematical modeling of biological systems, complementary methods such as direct simulation must be used to give a full understanding of the processes. As noted before, such works have been begun recently ([25]) for the photosynthetic apparatus.

Incidentally, from the mathematical and computational points of view the problem that is considered here is a challenging one (due to its complexity, large number of parameters and nonlinearity). It seems that, solving this problem by using other different algorithms and methods such as genetic algorithms, optimization methods, or analytical

approximations would be interesting. We are doing some implementation in this field to compare the speed and accuracy of the methods.

## REFERENCES

- [1] I. McConnell, G. Li, and G.W. Brudvig, "Energy conversion in natural and artificial photosynthesis," *Chem. Biol.* Vol. 17, pp. 434-447, 2010.
- [2] V. Balzani, A. Credi, and M. Venturi, "Photochemical conversion of solar energy," *ChemSusChem*, Vol. 1, pp. 26-58, 2008.
- [3] C. Chu and D. Bassani, "Challenges and opportunities for photochemists on the verge of solar energy conversion," *Photochem. Photobiolog. Sci.* Vol. 7, pp. 521-530, 2008.
- [4] N.S. Lewis, *Encyclopedia of Energy*, Elsevier, 2004.
- [5] K. Kalyanasundaram and M. Graetzel, "Artificial photosynthesis: Biomimetic approaches to solar energy conversion and storage," *Curr. Opin. Biotech.* Vol. 21, pp. 298-310, 2010.
- [6] T. Moore, A. Moore, D. Gust, M. Hambourger, G. Moore, A. Keirstead, and M. Gervaldo, "Artificial photosynthesis: Combining technology with biology for efficient solar energy conversion," ACS National Meeting Book of Abstracts, 2008.
- [7] Y. Koyama, T. Miki, X. Wang, and H. Nagae, "Dye-sensitized solar cells based on the principles and materials of photosynthesis: Mechanisms of suppression and enhancement of photocurrent and conversion efficiency," *Int. J. Molec. Sci.* Vol. 10, pp. 4575-4622, 2009.
- [8] Q. Wang, S. Ito, M. Grätzel, F. Fabregat-Santiago, I. Mora-Seró, J. Bisquert, T. Bessho, and H. Imai, "Characteristics of high efficiency dye-sensitized solar cells," *J. Phys. Chem. B*, Vol. 110, pp. 25210-25221, 2006.
- [9] A. Patrocínio, S. Mizoguchi, L. Paterno, C. Garcia, and N.M. Iha, "Efficient and low cost devices for solar energy conversion: Efficiency and stability of some natural-dye-sensitized solar cells," *Synth. Metals*, Vol. 159, pp. 2342-2344, 2009.
- [10] K. Nath and D. Das, "Production and storage of hydrogen: present scenario and future perspective," *J. Sci. Indust. Res.* Vol. 66, pp. 701-709, 2007.
- [11] J. Mussgnug, S. Thomas-Hall, J. Rupprecht, A. Foo, V. Klassen, A. McDowall, P. Schenk, O. Kruse, and B. Hankamer, "Engineering photosynthetic light capture: Impacts on improved solar energy to biomass conversion," *Plant Biotech. J.*, Vol. 5, pp. 802-814, 2007.
- [12] L. Beer, E. Boyd, J. Peters, and M. Posewitz, "Engineering algae for biohydrogen and biofuel production," *Curr. Opin. Biotech.* Vol. 20, pp. 264-271, 2009.
- [13] G. Rabinowitch E and Rabinowitch E, Govindjee, *Photosynthesis*, John Wiley, London, 1969.
- [14] Govindjee, J.T. Beatty, H. Gest, and J.F. Allen, Eds., *Discoveries in Photosynthesis*, Berlin/Heidelberg: Springer-Verlag, 2005.
- [15] G. Kurisu, H. Zhang, J.L. Smith, and W.A. Cramer, "Structure of the cytochrome b<sub>6</sub>f complex of oxygenic photosynthesis: tuning the cavity," *Science (New York, N.Y.)*, Vol. 302, pp. 1009-1014, 2003.
- [16] J.F. Allen, "Cytochrome b<sub>6</sub>f: structure for signalling and vectorial metabolism," *Trends Plant Sci.* Vol. 9, pp. 130-137, 2004.
- [17] E. Yamashita, H. Zhang, and W. Cramer, "Structure of the cytochrome b<sub>6</sub>f complex: quinone analogue inhibitors as ligands of Heme cn," *J. Molec. Biol.* Vol. 370, pp. 39-52, 2007.
- [18] D. Baniulis, E. Yamashita, H. Zhang, S.S. Hasan, and W.A. Cramer, "Structure-function of the cytochrome b<sub>6</sub>f complex," *Photochem. Photobiol.* Vol. 84, pp. 1349-1358, 2008.
- [19] M.A. Lomize, A.L. Lomize, I.D. Pogozheva, and H.I. Mosberg, "OPM: orientations of proteins in membranes database," *Bioinform.* (Oxford, England), Vol. 22, pp. 623-625, 2006.
- [20] S. Berry and B. Rumberg, "Kinetic modeling of the photosynthetic electron transport chain," *Bioelectrochem.* Vol. 53, pp. 35-53, 2001.
- [21] M. JalalKamali, G. Lebedeva, O. Demin, N. Beliaeva, G. Riznichenko, and A. Rubin, "A kinetic model of the cytochrome b<sub>6</sub>f complex. Evaluation of kinetic parameters," *Biofizika*, Vol. 49, pp. 1061-1068, 2004.

- [22] A. Hope, R. Huilgol, M. Panizza, M. Thompson, and D. Matthews, "The flash-induced turnover of cytochrome b-563, cytochrome f and plastocyanin in chloroplasts. Models and estimation of kinetic parameters," *Biochim. Biophys. Acta (BBA) - Bioenergetics*, Vol. 1100, pp. 15-26, 1992.
- [23] G. Riznichenko, N. Belyaeva, I. Kovalenko, and A. Rubin, "Mathematical and computer modeling of primary photosynthetic processes," *Biophys. J.*, Vol. 54, pp. 10-22, 2009.
- [24] P.R. Rich, P. Heathcote, and D.A. Moss, "Kinetic studies of electron transfer in a hybrid system constructed from the cytochrome bf complex and Photosystem I," *Biochim. Biophys. Acta (BBA) - Bioenergetics*, Vol. 892, pp. 138-151, 1987.
- [25] G.Y. Riznichenko, I.B. Kovalenko, A.M. Abaturova, A.N. Diakonova, D.M. Ustinin, E.A. Grachev, and A.B. Rubin, "New direct dynamic models of protein interactions coupled to photosynthetic electron transport reactions," *Biophys. Rev.* Vol. 2, pp. 101-110, 2010.
- [26] E.J. Haddadian and E.L. Gross, "A Brownian dynamics study of the interactions of the luminal domains of the cytochrome b6f complex with plastocyanin and cytochrome c6: The effects of the Rieske FeS protein on the interactions," *Biophys. J.*, Vol. 91, pp. 2589-2600, 2006.
- [27] O.S. Kniazeva, G.I. Kovalenko, A.M. Abaturova, G.I. Riznichenko, E.A. Grachev, and A.B. Rubin, "Multiparticle computer simulation of diffusion and interaction of plastocyanin with cytochrome f in the electrostatic field of the thylakoid membrane," *Biofizika*, Vol. 55, pp. 259-68, 2010.
- [28] E.L. Gross and I. Rosenberg, "A Brownian dynamics study of the interaction of phormidium cytochrome f with various cyanobacterial plastocyanins," *Biophys. J.*, Vol. 90, pp. 366-380, 2006.
- [29] I. Tremmel, E. Weis, and G. Farquhar, "Macromolecular crowding and its influence on possible reaction mechanisms in photosynthetic electron flow," *Biochim. Biophys. Acta (BBA) - Bioenergetics*, Vol. 1767, pp. 353-361, 2007.
- [30] A.B. Hope, "Electron transfers amongst cytochrome f, plastocyanin and photosystem I: kinetics and mechanisms," *Biochim. Biophys. Acta (BBA) - Bioenergetics*, Vol. 1456, pp. 5-26, 2000.
- [31] W. Chow and A. Hope, "Kinetics of reactions around the cytochrome b6f complex studied in intact leaf disks," *Photosynthesis Research*, Vol. 81, pp. 153-163, 2004.
- [32]

THIS PAGE IS INTENTIONALLY LEFT BLANK.